



THE KNIGHT COLLECTION



ALU-CLAD



Our alu-clad sash windows are a spring loaded design which gives them the look and feel of a traditional sliding sash windows however gives us more space for the two sashes enabling us to install larger glazing than previously possible as well as the extra aluminium capping. This design overcomes many of the disappointments often seen with aluminium clad sliding sash windows and offers a more energy efficiency window than is usually available in a sliding sash design.

Our Alu-clad sash windows are manufactured with a spring balanced mechanism giving the look and feel of traditional box weighted sash windows however saving on space. This design allows us for more space for the two sliding sash windows which in turn enables us to support thicker glazing up to 36mm. This means that we can now support triple glazing in our aluminium clad sash windows enhancing the overall U value of the windows. We also have a range of other possible glazing options such as standard argon filled double glazing and ultra thin Krypton filled double glazing units to give the look of single glazing with the energy efficiency of double glazing.

Manufactured with a timber core our sash windows have the majority of the features found on original sash windows from yesteryear including a thin top and mid rail, deep bottom rail, mechanical joints, authentic putty and glass lines as well as various astral and Georgian bars available.



AUTHENTIC CONSTRUCTION

Manufactured with a timber core our sash windows have the majority of the features found on original sash windows from yesteryear including a thin top and mid rail, deep bottom rail, mechanical joints, authentic putty and glass lines as well as various astral and Georgian bars available.

KEY DETAILS

- Spring loaded
- Bottom opening only
- External astragal bar is flat
- No sash horns

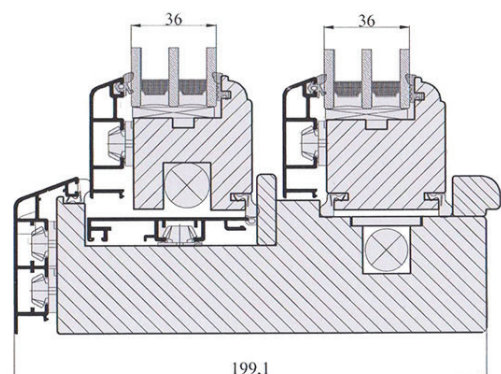

MATERIALS & FINISHES

Our alu-clad range of sash windows is available in a wide range of finishes. The timber frame can be stained in a wide range of colours or painted to any RAL colour. The colour of both the aluminium capping and timber frame can be either the same or different to create a dual colour window. This system give a wide range of options enabling you to custom build the perfect sash window.

PINE *Cost effective*

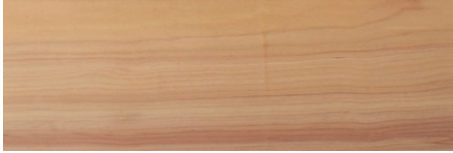

Preferably selected raw material for production of windows. Pine has a bright fresh colour, durability, excellent resistance to weather conditions and excellent thermal and acoustic insulation. Accessible, easy to handle and cost-effective. It is recommended for customers who value traditional solutions and economical use.

OAK *Durable & resistant*



The best building material out of native broad leaved trees, better than pine or even larch. Oak wood is hard, very durable and resistant to abrasion. It is characterised by high durability and resistance to changing moisture conditions. It has been widely appreciated all around the world for centuries.

MERANTI *Extremely resistant*

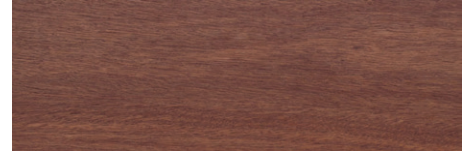

This exotic species of hardwood timber has extremely high resistance to weather conditions, especially against moisture. Not only durable, it's also very warm and quiet. Meranti wood density depends on the species and can range from 300 to 1050 kg/m³ with above 450 kg / m³ being preferred for consistent quality of the final product.

TEKNOS FINISHES

Our timber windows are coated with a 4 stage paint process from Teknos involving a wood preservative, primer, intermediate coat and topcoat. Teknos coatings are formulated to keep your products looking attractive year after year, resisting the elements, maintaining appearance and value. Each layer in the Teknos Aqua system has been carefully formulated both for its specific purpose and to work in synergy with the other products in the system to achieve maximum performance, including:

- Vacuum impregnation, wood preservative and combi primers product to preserve and prime the wood.
- End grain and construction joint fillers to protect the most vulnerable areas of exposed joinery.
- Intermediate products to fill the pores of coarser wood species, providing a more uniform surface for top coating.
- Flexible, micro porous topcoats for an attractive, durable yet flexible surface.



STAINED

Our different timber material can all be stained using a range of colours to enhance and protect the wood and achieve a look that fits your property.

PAINTED

We have a range of standard and custom RAL colours that can be applied to your new timber windows to achieve your desired finish.



SASH WINDOW HARDWARE

We have a range of standard hardware available in our timber sash windows all available in various finishes. Looking for something different? We also offer a range of bespoke options custom made to suit your requirements.

Sash window hardware can often be dictated by the style of property, we understand the need to replicate the original windows within your home and can design your new hardware to match.

Pole Rings



Polished Chrome



Satin Chrome



Polished Brass



White

Hook Lifts



Polished Chrome



Satin Chrome



Polished Brass



White

Fitch Fastener - Locking



Polished Chrome



Satin Chrome



Polished Brass

Fitch Fastener - Non-Locking



Polished Chrome



Satin Chrome



Polished Brass

Modern Locking



Polished Chrome



Satin Chrome



Polished Brass



White

Modern Non-Locking



Polished Chrome



Satin Chrome



Polished Brass



White

Angle Lock - Limit Stops



Polished Chrome



Satin Chrome



Polished Brass



White

Push Vent - Limit Stops



Polished Chrome



Satin Chrome



Polished Brass

Push Vent Lock - Limit Stops



Polished Chrome



Satin Chrome



Polished Brass

SASH WINDOW ARCHITRAVE

Many Georgian, Victorian and Edwardian home are finished internally with beautifully decorative woodwork which adds to the beauty of the sliding sash windows.

Standard Architrave Options

Ogee



Taurus



Pencil Round



Outline Drawings

Ogee - Outline

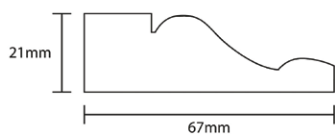

Taurus - Outline

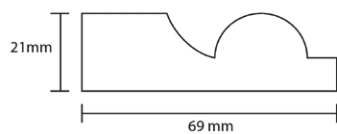

Pencil Round - Outline

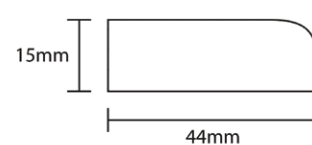

Upgrade Architrave Options

Regency



Victorian



Classic



Outline Drawings

Regency - Outline

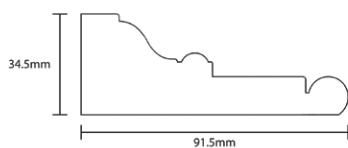

Victorian - Outline

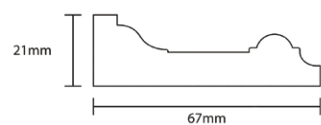

Classic

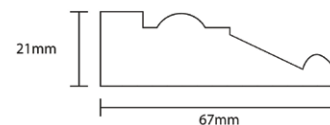



THE KNIGHT COLLECTION



John Knight Glass
Chester Road
Heswall, Wirral
CH60 3RZ

Tel: 0151 342 2266
Fax: 0151 342 2337
Email: info@johnknightglass.co.uk
Online: www.johnknightglass.co.uk

Directors: JS Knight, BJ Knight, MS Spereall. Company Registration Number 1898755